

The Performance Test of Casters

Static Load Test

Apply a load of three times the maximum load written in the catalog on the caster for 3 minutes, to check abnormalities. It will provide reference data for load bearing capacity.

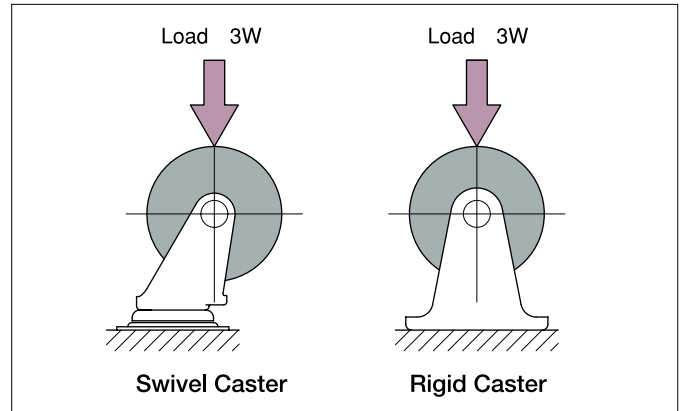

Running Test

Apply the maximum load on the caster and roll it on a rugged steel drum for a certain distance, to check wheel performance. It will provide reference data for the rolling performance of a wheel.

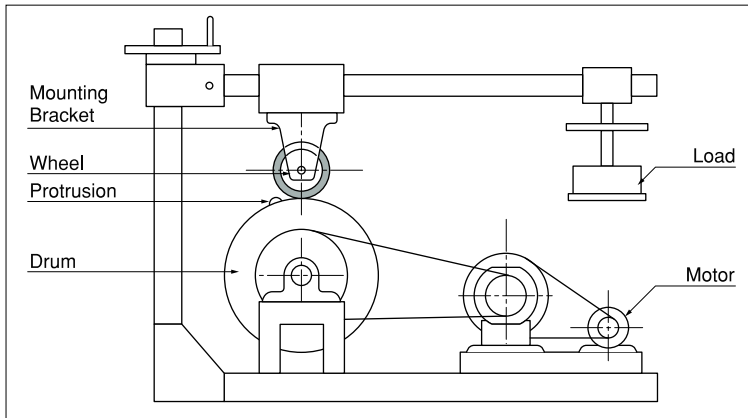

Starting Performance Test

Attach casters to a cart, and place a load onto the cart. Then, measure starting resistance. You can check starting performance and swivel starting performance.

