

KHW/KW Type

Size: 150mm~200mm

Towing Rigid Bracket

RGKHW-200

SHVKW-200

Unit: mm

Size 	Model Number	Wheel	Bearing	Load Capacity		Tire Width R	Shaft Diameter D	Overall Height H1	Plate Size F1/F2	Mounting Hole Spacing P1/P2	Plate Hole d	Weight (g)	
				(daN)	(kgf)								
150	RGKHW-150	Aluminum Rim·Rubber	B/B	300	306.0	50	20	198	140/96	100/56	11	2,650	
	RKHW-150	Aluminum Rim·Urethane	B/B	500	510.0							2,760	
	RFKHW-150	Steel Rim·Urethane	B/B									2,820	
200	■KHW-200 Shaft Diameter 25												
	RGKHW-200	Steel Rim·Rubber	B/B	410	418.2	63	25	250	151/102	112/63	14	4,810	
	RFKHW-200	Steel Rim·Urethane	B/B	600	612.0							4,820	
	■KW-200 Shaft Diameter 20												
	SVKW-200	Rubber	B/B	250	255.0	45	20	250	151/102	112/63	11	3,500	
	SHVKW-200	High-Rebound	B/B									3,500	

Bearing: B/B -- Steel bearing

The shaft includes a split pin for preventing loosening.

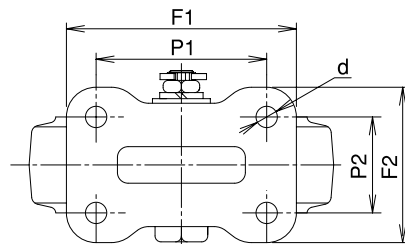
【Bracket Dimensions】

Unit: mm

Size 	Load Capacity		Bracket Height H	Bracket Width B	Weight (g)
	(daN)	(kgf)			
150	550	561.0	123	60	1,520
200	■KHW-200 Shaft Diameter 25				
	660	673.2	150	71	2,250
	■KW-200 Shaft Diameter 20				
	420	428.4	150	56	1,750

* The shaft set is included in the bracket.

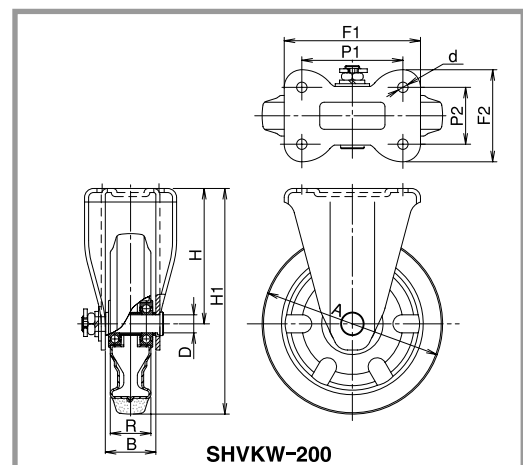
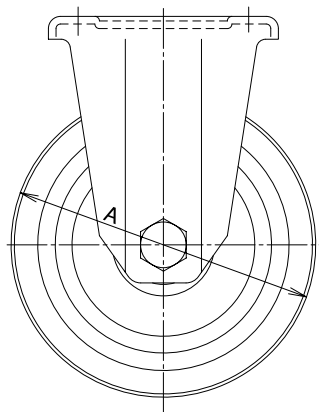
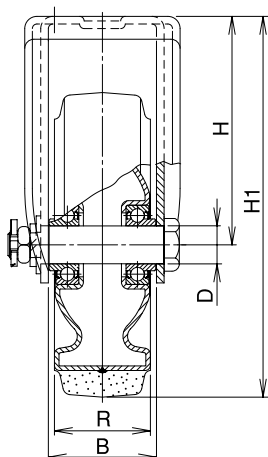
SHVKW-200